



CE-09-0413-02

CE-09-0316-01



Mounting dimension (Unit:mm)

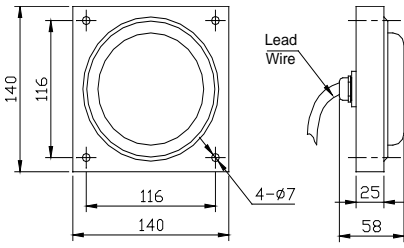

ABC-16/ABC-16FA

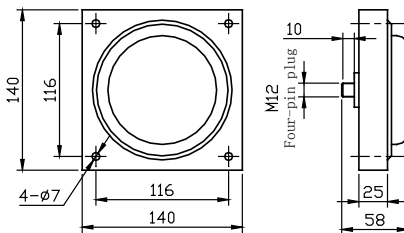

ABC-16A/ABC-16F

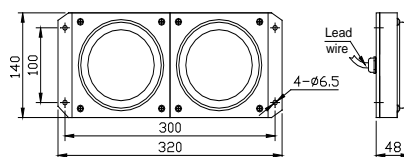

ABC-16B

Applications

Specially design for all kinds of hoisting machinery

Main Functions and features

- Lamp body constructed of die cast aluminum, light weight, corrosion resistance, sealed, waterproof and dustproof.
- Super bright LED design, lifetime more than 100,000hrs.
- Flexible combination mode for wide application



Specifications:

Operating voltage	AC110V~AC240V/AC12V DC12V/DC24V/DC48V	Frequency	50Hz ~ 60Hz
Power	≤5W	Color	Red,yellow, green,blue, white(optional)
Visible distance	>300m	LED Lifetime	≥100,000h
Wiring type	Cable/plug (optional)	Own lead length	8m (customized)
Operating temperature:	-30°C ~ +70°C	IP Protection	IP65
Relative humidity	10% ~ 95% (no condensing)	Material	Main body : Aluminum alloy.

Installation and Operation

- Check whether the operating voltage complies with the rated voltage of the warning light
- Secure the light body on a smooth surface with enough mechanical strength using four M6 screws.
- Connect the power line according to the instruction table.
- Verify the connections of the power line, the corresponding lamp start work.

Wiring diagram

Wiring diagram				
Wiring type	Wiring diagram			
Cable Three-core cable 3X0.5mm ²	AC220V	Red cable L	Blace cable N	Yellow-green cable ⊥
	DC24V	DC24V+	DC24V-	
Plug (Positive view)	Voltage	DC24V		AC110V-AC240V
	Plug		1, 2-NC 3-DC24V- 4-DC24V+	

Notice

- The part of material of products is PC(like lamp cover and lamp shell), so it cannot direct or indirect touch the organic solvent, such as industrial alcohol, banana oil, isopropyl alcohol, carbon tetrachloride, cyclohexanone and so on, otherwise, the product will be corrosion.
- Please read the instruction manual carefully before operation.
- Ensure that the power connection part is correct.
- If there are any questions when, please contact us.

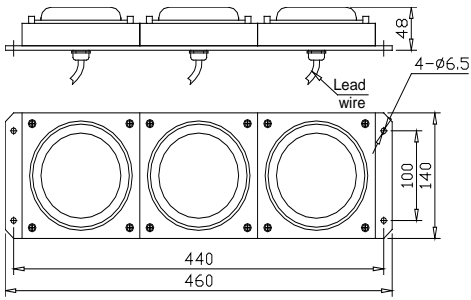

ABC-16C

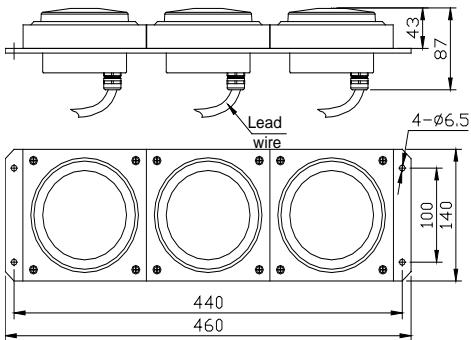

ABC-16C(AC380V)

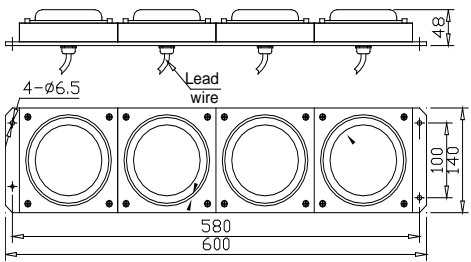

ABC-16D

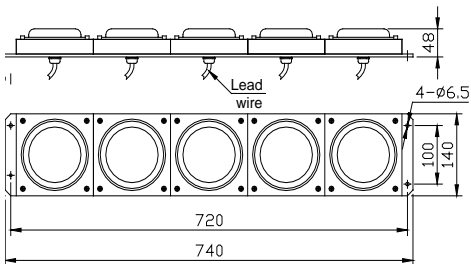

ABC-16E

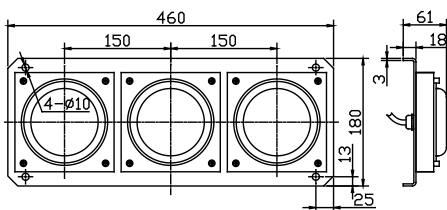

ABC-16C Customized light 1

Model table

Model	Combination type	Electric current	Wiring type	Weight (kg)
ABC-16	General	<300mA	One 8m Three-core cable	1.5
ABC-16A	ABC-16with Four-core cable	<300mA	Four-core plug/ One Three-core cable	1
ABC-16B	ABC-16 with 2 lights	<500mA	Four-core plug/Two Three-core cable	3.8
ABC-16C	ABC-16 with 3 lights	<700mA	Four-core plug/Three Three-core cable	5.7
ABC-16D	ABC-16 with4 lights	<1A	Four-core plug/Four Three-core cable	7.6
ABC-16E	ABC-16 with 5 lights	<1.2A	Four-core plug/Five Three-core cable	9.5
ABC-16F	ABC-16with Four-core cable and grind glass	<300mA	Four-core plug	1
ABC-16FA	ABC-16with 8m cable and grind glass	<300mA	One 8m Three-core cable	1.5

Application

