

Mounting size (Unit : mm)

Wiring type 1 :

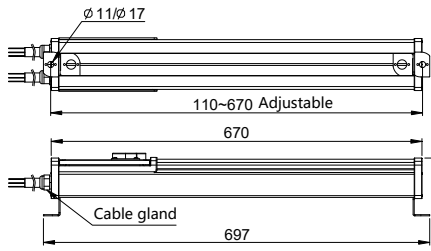

Wiring type 2 :

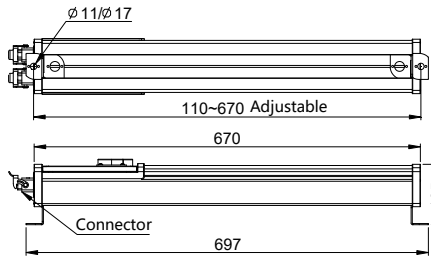

Light distribution curve

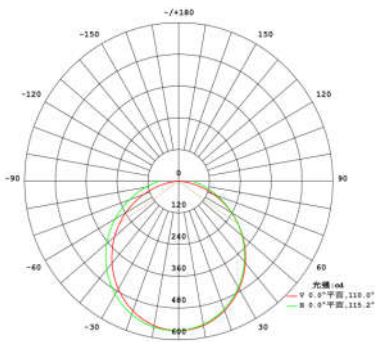

Application

Designed for wind turbine (tower, nacelle) inside lighting and can be used as a supplementary lighting of indoor environment

Main functions and features

- Soft light beam: PC grain housing makes the light beam softly, to protect eyes
- Long lifetime and environmental friendly: The life of LED can reach more than 50,000hrs, and the light can save 50% energy than commonfluorescent lamp
- Integrated design, convenient for site installation : The lamp, junction box and socket are integrated to one base which is convenient for site installation and future maintenance
- Socket configuration is optional: Standard configuration is 10A multi-function socket. Other socket can be customized.
- Emergency function: The light works normally one it is powered on and the battery is charged. It will automatically be emergency when it blacks out. The emergency time is 90 minutes

Specifications

Operating voltage	AC110V-AC264V	Frequency	50Hz ~ 60Hz
Power consumption	20W	LED life	≥50,000hrs
CCT	5500K-6000K	CRI	Ra>72
Luminous flux	1500 lm	weight	1.6 KG
Working temperature	-30°C ~ +50°C (Emergency) -40°C ~ +50°C (normal lighting)	Relative humidity	10% - 95% (no coagulation)
		IP Protection	IP65
storage temperature	-40°C ~ +70°C	Material	Housing: PC Base: aluminum alloy

Operation and installation

- Check whether the power supply complies with rated voltage of the light.
- Secure the light on a smooth surface which has enough strength using M10 screws.
- Equipped with connectors, and connect the power cable and output cable throughthe connectors.
- Power cable wiring diagram see left side

L1 ,and N1 input for normal lighting,

L2 and N1 input for emergency,

L3and N2 for socket;

ON/OFF of L1 can contral ON/OFF of the lamp, when the power blacks out, the lamp will automatically work in emergency function.

Terminal Diagram

Wiring type 1 : Wiring type 2 :

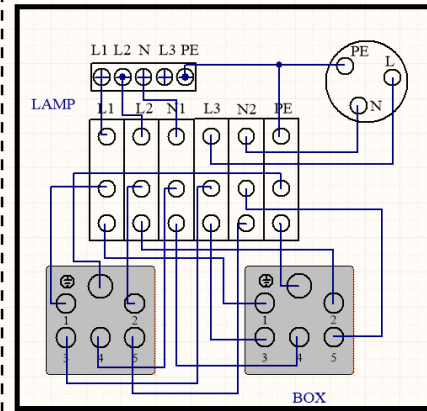
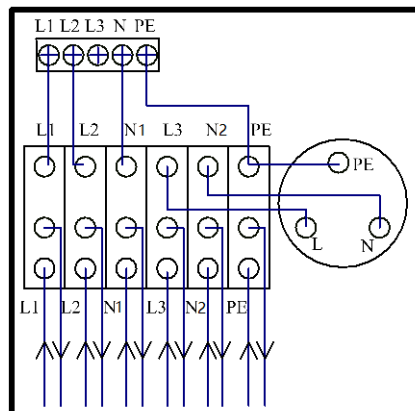

Notice: 1--L1, 2--L2, 3--L3,4--N1, 5--N2, 6--PE

Application



Installation instruction

Wiring type 1 Installation instruction :

Mount type 1:

Wall mount - Vertical

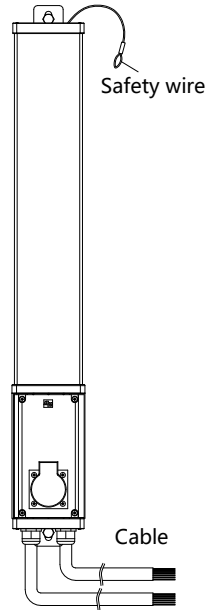

Mount type 2:

Ceiling mount



Mount type 3:

Wall mount - Horizontal

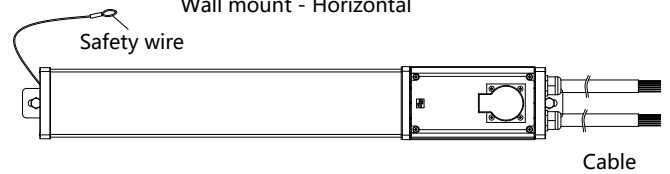

Wiring type 2 Installation instruction :

Mount type 1:

Wall mount - Vertical

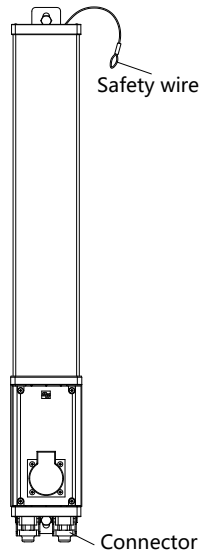

Mount type 2:

Ceiling mount

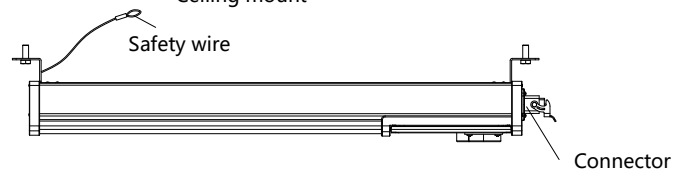

Mount type 3:

Wall mount - Horizontal

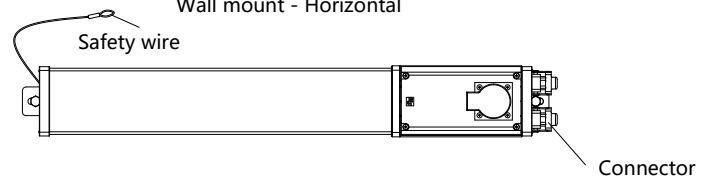

Notice

- The part of material of products is PC(like lamp cover and lamp shell), so it cannot direct or indirect touch the organic solvent, such as industrial alcohol, banana oil, isopropyl alcohol, carbon tetrachloride, cyclohexanone and so on, otherwise, the product will be corrosion.
- Temperature rise when light working is normal phenomenon.
- Please do not open any components inside by yourself.
- As its sealed structure,do not disassemble the lamp without professional people. Otherwise, the warranty is invalid.
- Polymer Lithium-Ion battery inside the lamp is a consumable, the cycle life(IEC61951-2/2011/7.5.1.2)is 500 times.It is recommended to conduct charge-discharge one time every 3 months once a year.