

AE422

Laser Anti-collision System



Products description and application



The AE422 series anti-collision system adopts laser ranging technology, has excellent ambient light immunity, matches the rugged and durable structural shell and provides protection for cranes such as traveling cranes, RMG, RTG, STS etc. running on the track. Collision solution to ensure that there is no collision between cranes.

Laser complies with IEC/EN 60825-1:2014.



Features

- Voice Prompt Pre-alarm and Alarm, Pre-alarm and Alarm point is adjustable.
- Mini display panel displays distance.
- Suit for use 2 sets 4~20mA signal anti-collision sensors, it is flexible to set measure distance.
- Both direction two levels NO or NC switch signal output.
- Wide range of voltage: AC85 ~ AC265V.
- Maximum monitoring distance up to 50m.
- The laser level is Class I

AE422C General Specifications

Input Voltage	AC85V~AC265V	Storage Temperature	-40°C ~ +75°C
Frequency	50~60Hz	Operating Temperature	-30°C ~ +70°C
Power Consumption	< 10W	Ambient Humidity	0% ~ 95%
Range	0.2m~50m	Application	Indoor
Tolerance	±0.1 m	Weight	0.5Kg
Action-time	0.5s	Material	ABS
Sound level	80dB	Display resolution	0.1m
Muti-signal output	Voice Prompt alarm, digit communication (optional) Both direction two levels switch signal output. (NO or NC)		
Resistance	12A 125VAC 7A 250VAC 7A 30VDC		
Display	Content: distance Refreshing frequency : 2 frequency per second		

AE422A General Specifications

Input Voltage	DC12~30V	Storage Temperature	-40°C ~ +75°C
Output current	< 100mA	Operating Temperature	-30°C ~ +55°C
Inversion frequency	333...6Hz	IP Rate	IP65
Signal output	4~20mA	Weight	0.48Kg
Lamp Source	Red laser	Housing	SUS304+PC
Detection distance	0.2m~50m (with "diamond grade" reflective film)	Spot diameter	15mm×15mm(2m)

AE422 Laser Anti-collision System



AE422A General Specifications

Laser level	Level 1(EN 60825-1)		
-------------	---------------------	--	--

AE411B General Specifications

Dimensions	330x330mm	Material	aluminum
------------	-----------	----------	----------

Mounting dimensions

AE422C host installation
Unit of length : mm

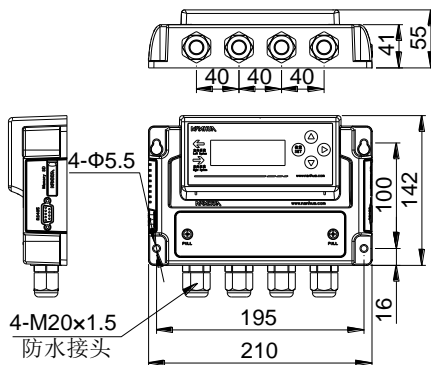

Precautions for host installation:

- 1 . Make sure power supply match with rated voltage.
- 2 . Parallel mounting surface to displayer.
- 3 . Use 4 pcs M5 screws to fix displayer, mounting surface should have enough machinery strength.
- 4 . Unfasten screws and remove the plate.
- 5 . Connect the power wire, data wire and control wire through the gland, connect the power wire and signal wire in accord with terminal label.
- 6 . Fasten useless terminals to avoid short circuit

AE422A sensor installation
Unit of length : mm

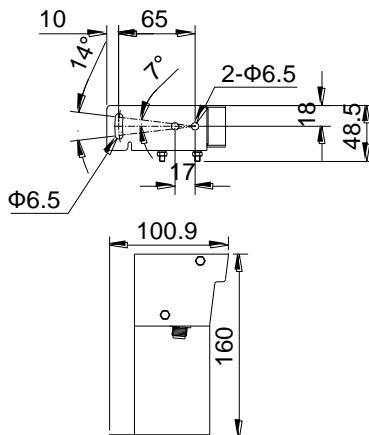

Precautions for sensor installation:

- 1 . Use 2 pcs M6 screws to fix sensor, mounting surface should have enough machinery strength.
- 2 . Laser fine-tuning can be done through two waist holes in the bracket
- 3 . Cable length can be customized.

AE422 Laser Anti-collision System



AE411B reflector installation
Unit of length : mm

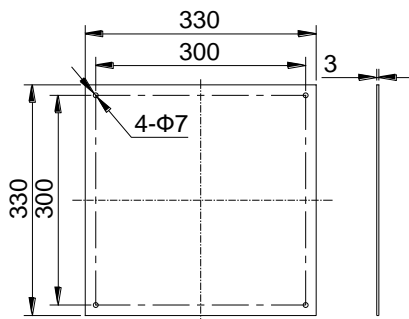

Precautions for reflector installation:

1. Use 4 pcs M6 screws to fix sensor, mounting surface should have enough machinery strength.
2. Adapter bracket can be customized.

AE422 Laser Anti-collision System installation diagram :

Taking a traveling crane as an example, a traveling crane needs to be equipped with one host, two sensors, and two reflectors

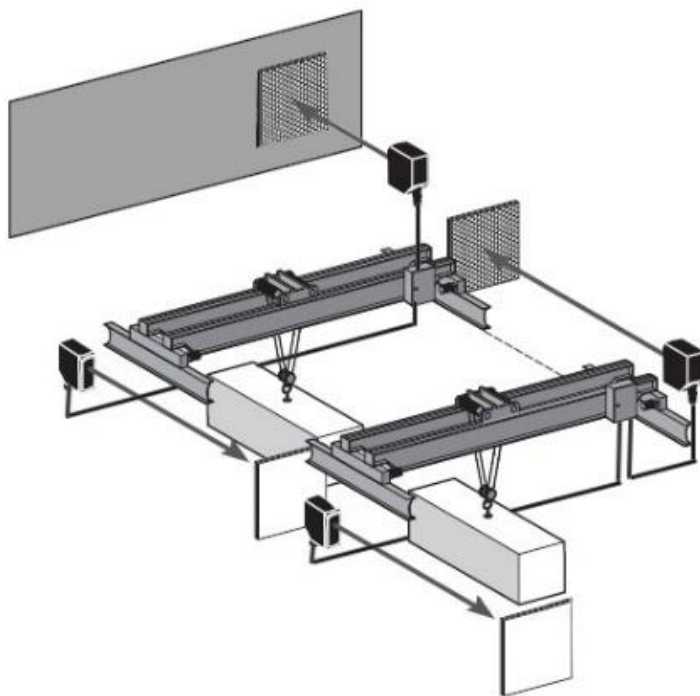

Schematic diagram of sensor bracket adjustment:

1. The sensor can be adjusted $\pm 5^\circ$ degrees in the vertical direction.
2. The sensor can be adjusted $\pm 7^\circ$ degrees in the horizontal direction.

AE422 Laser Anti-collision System

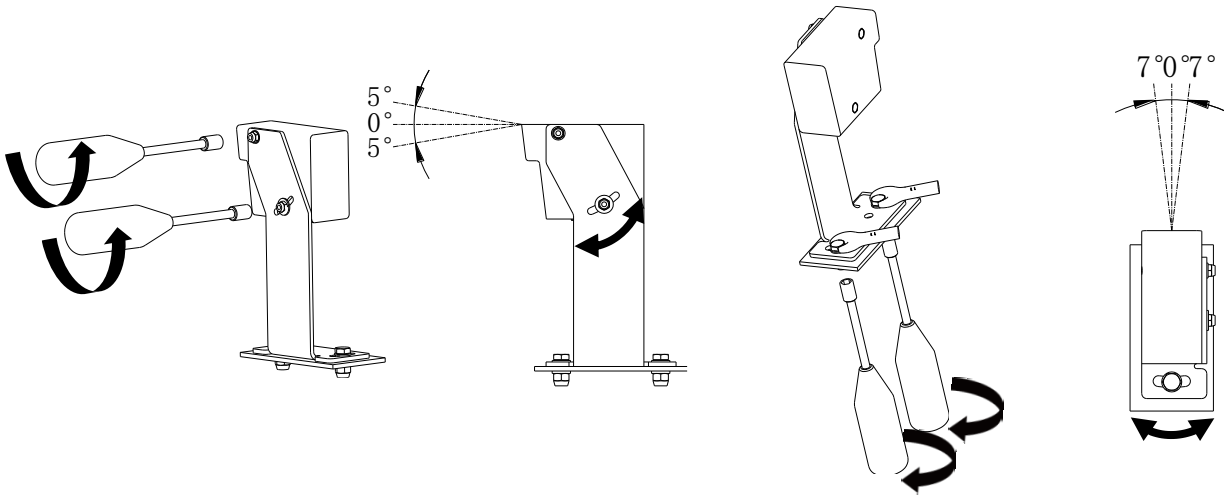

Wiring diagram

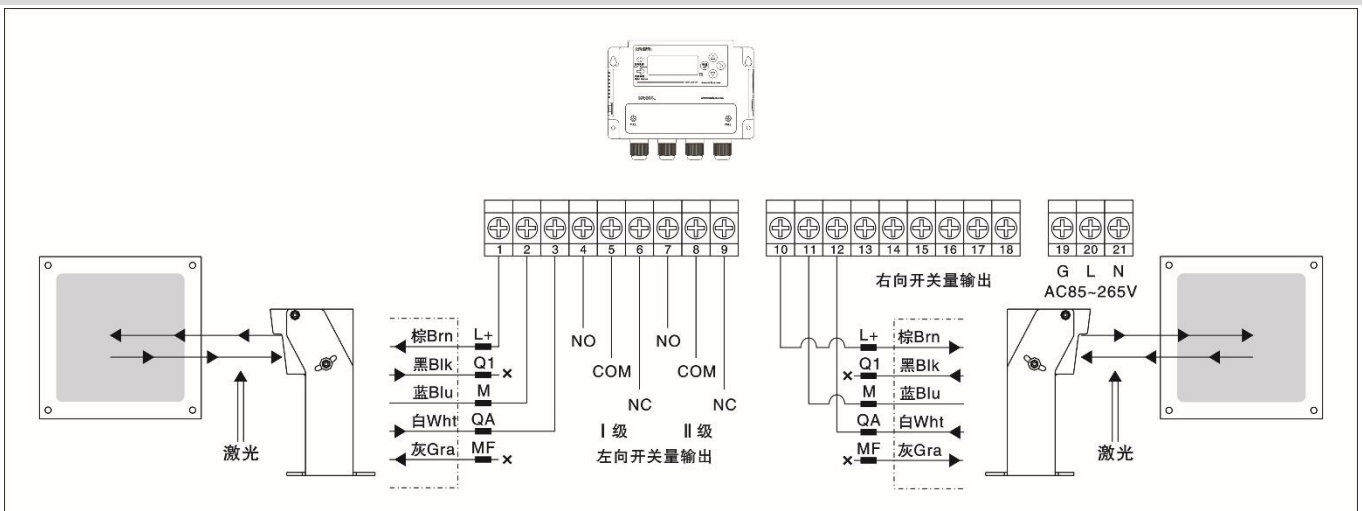

Commissioning instructions

一、Display function:

- AE422C display can be connected with two sensors, when display received current signal less than 3.5mA or more than 20mA, it displays "----" output 20.5mA in the same time, means non sensor connect or detect distance is over standard; when display receive 3.5mA current signal, it displays 0m, output 3.5mA in the same time, means detect distance is less than 0.2m.
- It displays left distance data when only connect left sensor.
- It displays right distance data when only connect right sensor.
- When connect both left and right sensors, it displays data of moving direction when equipment is moving; ,it displays near side data when equipment stop.
- When sensor detect actual distance data is less than pre-alarm or alarm point, display will broadcast speech alarm. In normal condition, long press ▲ or ▼ button to adjust volume.
- The left and right sensor input parts of the display have current synchronization output modules. The sensor inputs current, and the display converts the current value into distance information and displays it through the digital tube. .
- (Optional function)Display has RS485 interface, RS485 continous output 1 frequency per second when connect sensor.

二、Left and right distance display debugging:

- Connect left sensor only for debugging left system, if display ----, it means bad contact of sensor, please check whether cable connect well or the display gets damaged.
- Connect right sensor only for debugging right system, if display ----, it means bad contact of sensor, please check whether cable connect well or the display gets damaged.
- If the above left and right sensors are connected normally, you can connect left and right sensors at the same time.

AE422

Laser Anti-collision System



三、 Mode and parameter setting:

a is cipher of timing system setting mode: cipher is A16.3.

b is pre-alarm point setting, i.e. display "b04.0", it means pre-alarm point is 4m.

When host machine display distance less than pre-alarm point, AE422C will alarm sound.

c is alarm point setting, i.e. display "C02.0", it means alarm point is 2m.

When host machine display distance less than alarm point, AE422C will alarm sound.

d is measurement range setting, i.e. display "d50.0", it means measurement range is 0~50m.

If sensor range is 4~20ma corresponding 0~20m, please set C as "d20.0".

If sensor range is 4~20ma corresponding 0~50m, please set C as "d50.0". (others are the same).

- Configuration (Note : after entering to the setting mode, If without any motion in the button after configure 10s will auto back to the normal display mode)

a mode : constant press SET button for 3s until display A00.0, "A" word flash.

b mode : after into A mode or C mode , constant press ▼ or short press ▲, until display bXX.X, "b" word flash.

c mode : after into A mode or b mode , constant press ▼ or short press ▲ until display CXX.X then off , "C" word flash.

d mode: after into A mode or b mode , constant press ▼ or short press ▲ until display dXX.X then off , "d" word flash.

- Parameter setting

At first should enter the setting mode, short press ▶ until the cursor to position you want revise , then short press ▼ or short press ▲ to revise the corresponding data (the corresponding data will change repeating) , after revised well then press SET button 3 seconds to confirm.

Note: In normal condition, press ▼ and ▲ button 3 seconds in the same time to recovery factory setting

四、 Factory parameter setting:

No.	Parameter	Figure
1	Measurement range	0.2m~50m
2	Pre-alarm point	4m
3	Alarm point	2m

Notice

- The shell of the host and the mirror surface of the sensor are made of engineering plastics. They must not be in direct or indirect contact with organic solvents such as industrial alcohol, banana water, isopropyl alcohol, carbon tetrachloride, and cyclohexanone, otherwise they will be corroded and cracked.
- The host AE422C is only suitable for indoor installation
- Ensure power supply is corresponding to AE422C rated voltage.
- Please connect wires follow wiring diagram, avoid short circuit.
- Temperature rise inside the control box is normal phenomenon
- Keep reflector and sensor lens clear, dirty items or frost will impact product stability, serious case products failure, suggest clear them every 6 months.
- Please read the manual carefully before use, please do not open any components inside by yourself.
- Please contact us if you have any questions.

How to Order

Set P/N	Name	Model	Rated voltage	Description
1100024	Laser Anti-collision System	AE422U	AC85V-265V	With two distance measuring sensors; host normally closed switch output; two-way dual control; with two 330mm*330mm reflectors (with reflective film inside the size of 242mm*242mm); digital tube display distance; voice prompt; detection distance 0.2m -50m; the host can set the alarm distance
1100023	Laser Anti-collision System	AE422D	AC85V-265V	With a distance measuring sensor; host normally closed switch output; one-way dual control; with a 330mm*330mm reflector (with reflective film inside the size of 242mm*242mm); digital tube display distance; voice prompt; detection distance 0.2m- 50m; the host can set the alarm distance
Accessories	Name	Model	Rated voltage	Description
1100022	Anti-collision controller	AE422C	AC85V-265V	Two 4-20mA inputs; two normally closed switch outputs; alarm distance can be set;
1100021	laser sensor	AE422A	DC12V-30V	Signal output: 4-20mA output corresponds to 0.2m-50m; with indicator light; IP65

AE422

Laser Anti-collision System



1100015	Anti-collision reflector	AE411B	330MM*330MM*3mM aluminum plate (coated on both sides)
1100340	Laser Anti-collision Device Cable	PW5203	black RVV; approximate outer diameter 5mm; 5*0.2mm ² ; brown, blue, black, white, gray; -30°C~70°C; wire length 20m
1100332	Laser Anti-collision Device Cable	PW5201	black RVV; approximate outer diameter 5mm; 5*0.2mm ² ; brown, blue, black, white, gray; -30°C~70°C; wire length 25m
1100330	Laser Anti-collision Device Cable	PW5201	black RVV; approximate outer diameter 5mm; 5*0.2mm ² ; brown, blue, black, white, gray; -30°C~70°C; wire length 35m
1100339	Laser Anti-collision Device Cable	PW5202	black RVV; approximate outer diameter 5mm; 5*0.2mm ² ; brown, blue, black, white, gray; -30°C~70°C; wire length 40m
1100342	Laser Anti-collision Device Cable	PW5204	black RVV; approximate outer diameter 5mm; 5*0.2mm ² ; brown, blue, black, white, gray; -30°C~70°C; wire length 50m
1100331	Laser Anti-collision Device Cable	PW5201	black RVV; approximate outer diameter 5mm; 5*0.2mm ² ; brown, blue, black, white, gray; -30°C~70°C; wire length 55m
1100329	Laser Anti-collision Device Cable	PW5201	black RVV; approximate outer diameter 5mm; 5*0.2mm ² ; brown, blue, black, white, gray; -30°C~70°C; wire length 60m
1100337	Laser Anti-collision Device Cable	PW5201	black RVV; approximate outer diameter 5mm; 5*0.2mm ² ; brown, blue, black, white, gray; -30°C~70°C; wire length 70m
1100328	Laser Anti-collision Device Cable	PW5201	black RVV; approximate outer diameter 5mm; 5*0.2mm ² ; brown, blue, black, white, gray; -30°C~70°C; wire length 85m
1100336	Laser Anti-collision Device Cable	PW5201	black RVV; approximate outer diameter 5mm; 5*0.2mm ² ; brown, blue, black, white, gray; -30°C~70°C; wire length 90m
1100333	Laser Anti-collision Device Cable	PW5201	black RVV; approximate outer diameter 5mm; 5*0.2mm ² ; brown, blue, black, white, gray; -30°C~70°C; wire length 115m
1100335	Laser Anti-collision Device Cable	PW5201	black RVV; approximate outer diameter 5mm; 5*0.2mm ² ; brown, blue, black, white, gray; -30°C~70°C; wire length 160m
1100343	Laser Anti-collision Device Cable	PW5201	black RVV; approximate outer diameter 5mm; 5*0.2mm ² ; brown, blue, black, white, gray; -30°C~70°C; wire length 180m
1100338	Laser Anti-collision Device Cable	PW5201	black RVV; approximate outer diameter 5mm; 5*0.2mm ² ; brown, blue, black, white, gray; -30°C~70°C; wire length 205m
1100812	Laser Anti-collision Device Cable	PW5201	black RVV; approximate outer diameter 5mm; 5*0.2mm ² ; brown, blue, black, white, gray; -30°C~70°C; wire length 230m

Thanks for choosing our products, NANHUA Electronics is the professional brand of signal transmission and high quality industrial lighting which is trusted and loved by global users from various industries. Read and understand these instructions completely and carefully. Wrong installation and operation may lead to fires, electric shock, and others. Due to our continued efforts to improve our products, product specifications are subject to change without notice. ©NANHUA Electronics Co., Ltd. All rights reserved. www.nanhua.com