

# FR104 Obstruction Light Controller



Control cabinet



Accessory: PJ003 photocell (optional)

## Products description and applicaiton

Mainly applied to aviation obstruction light's fault alarm monitoring, ON/OFF switch and control function including flash rate adjustable for tower(transmission, telecom, microwave etc.), chimney(power plant, coking plant, chemistry plant etc.), tall buildings, large bridges, large port machinery, large engineering machinery and wind turbine etc., it also could be used to control the street lamp.

This control cabinet only for NANHUA aviation obstruction light's,not guarantee similar control functions for other non-match avation obstruction lights.

## Features

- AWL's flash synchronously.
- Fault alarm indicators on the panel and alarm signal output.
- Alarm signal with dry contact passive output.
- Auto-Manual switchable, if don't need photocell automatically switch function, it could be switched to manual control.
- Main& standby fault switch function :when the main light fails, will switches to the standby light automatically.
- External photocell switch PJ003, photocell fault alarm function(optional).
- Optional GPS synchronization function.

## Main Specifications

Electric parameter		Mechanical structure parameter	
Input voltage	AC100-240V <sup>1</sup>	Material	Cold rolled plate with powder spray (RAL7038) <sup>2</sup>
Output voltage	DC48V	Net weight	3.5 kg(AC) ,2.5 kg(DC)
Frequency	50Hz/60Hz	Storage temperature	Ta-40℃~+70℃
Load power	20W-240W <sup>3</sup>	Operating Temperature	Ta-40℃~+55℃
Surge/Lightning	IEC61000-4-5 L- L 3kV	Ambient Humidity	10% ~ 95% RH(No condensation)
Protection	IEC61000-4-5 L-G 6kV	IP Rate	IP65
Electrostatic	IEC61000-4-2 Contact	Color	Grey(RAL7038)
Discharge	discharge 8kV		
Functional parameter			
Max. control lights	4 units <sup>4</sup>	Control mode	Steady burning/Flashing
Single load power	4W-100W	Flash rate	20FPM,30FPM,40FPM and 60FPM
Alarm output	Dry contact (Relay) output		

1. Specific voltage refers the order number AC100~240V/DC48V.

2. For special occasions, the material can be customized for SUS 304 spray (RAL7038) or SUS 316 spray (RAL7038).

3. The actual power consumption of the controller will vary according to the specific loading lights power, depending on the orders.

4. When the work mode is the main & standby mode, the number of control loops is not more than 2 ways, which is in accordance with the order.

## Mounting dimensions

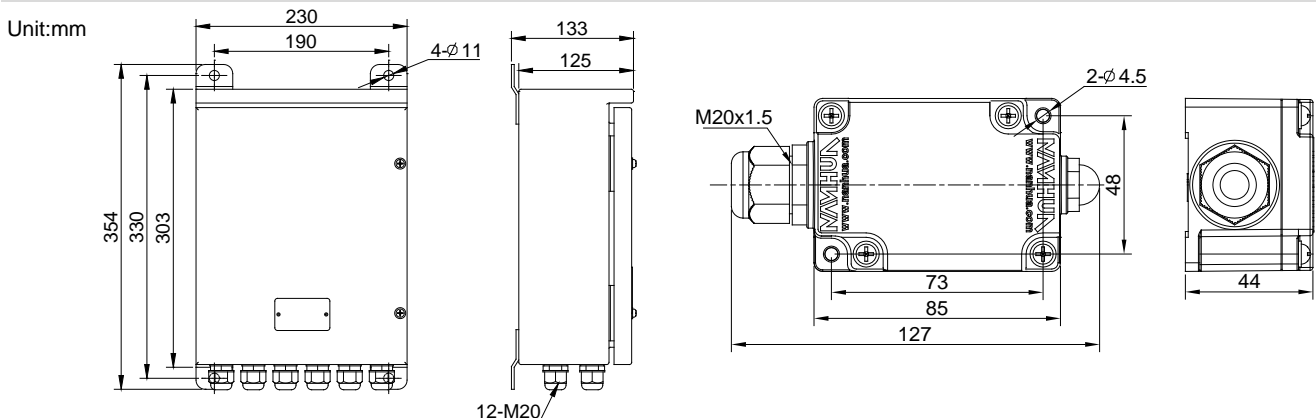

# FR104

## Obstruction Light Controller



### Installation method

- Please make sure that the mounting surface or mounting bracket is strength enough, the installation location should have enough space, and could open the controller door regularly.
- Using 4 sets bolt(M10 bolt, plain washers, spring washer, M10 nut) to fix the controller on the mounting surface or bracket. Notes: Please use stainless steel bolt, ensure the fixation strength.
- Using 2 sets M4 screw assemblies PJ003 photocell fix outdoor mounting plate or bracekt, When installing, do not touch the photoreceptor of the photocell to the nearby light source and it is not blocked by nearby objects (suitable for photocell); Notes: Please use stainless steel bolt, ensure the fixation strength.
- Put the power cable through the waterproof cable gland from the cabinet bottom side, use a smaller size screwdriver, press the spring to connect the wire into terminals, please connect according to the marking inside the cabinet.
- Make sure to screw down the cable gland after wiring to be waterproof.
- Waterproof nylon joint line at the bottom of the wire diameter is  $\phi 6-\phi 12.5\text{mm}$ .
- Make sure the input voltage is corresponds to the controller operating voltage.
- The GPS antenna should be installed outdoors in an open and relatively unobstructed position. The synchronization function test can take up to 30 minutes (suitable for GPS).
- Don't open any parts of the controller when it is working to avoid any anger!
- Must be power off before wire connection to avoid any danger!

### Wiring diagram

#### Description

U: Power supply  
 SPD1: AC lightning protector  
 Q1: AC breaker  
 FR10: Control cabinet

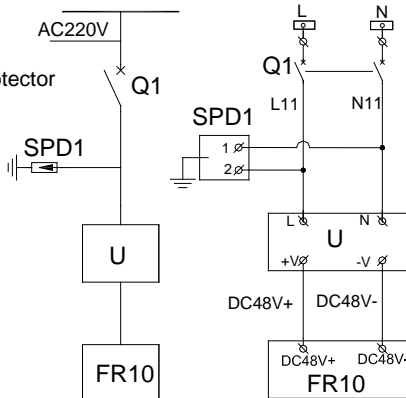

AC power control diagram

#### Description

U: Power supply  
 SPD1: DC lightning protector  
 Q1: DC breaker  
 FR10: Control cabinet

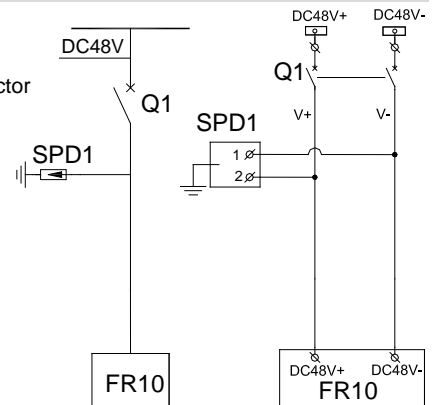

DC power control diagram

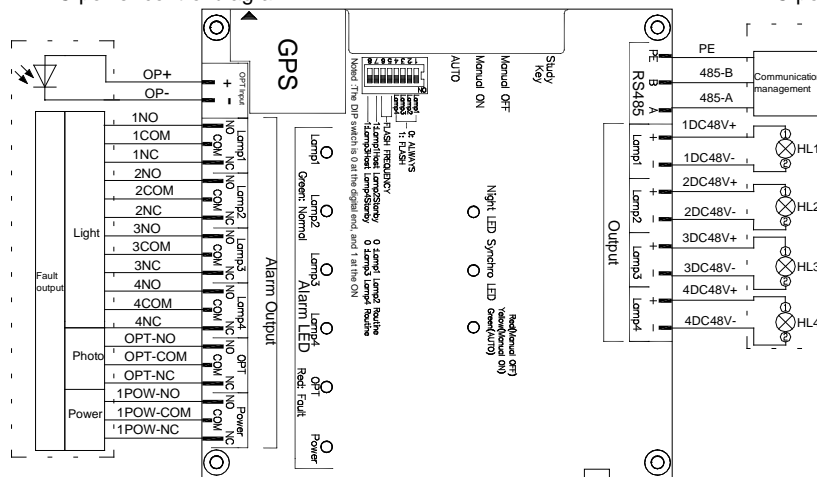

Wiring diagram

### Terminal wiring

- Power supply terminals, product for DC type and AC type, the info as below:

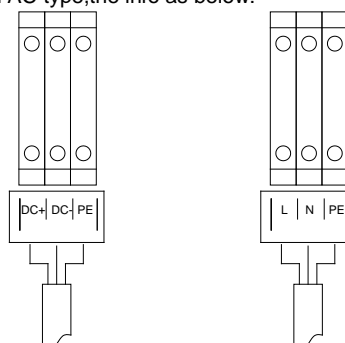

# FR104 Obstruction Light Controller



•Control branch output terminal as shown below (“Lampx-” connect negative load, “Lampx+” connect positive load):

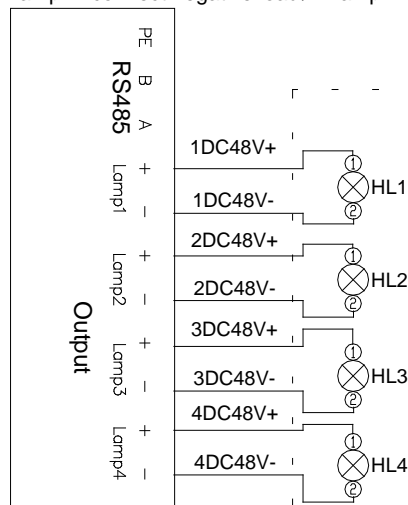

## Operation Instruction

### • Manual/Auto switch.

Use the black Dial switch to adjust AUTO, ON & OFF three status.

Toggle the switch to the AUTO position, the controller works in a auto status, it will turn off the light in the daytime and turn on the light at the night time.

Toggle the switch to the ON position, the controller works in a manual on status, it turns on the light:

Toggle the switch to the OFF position, the controller works in a manual off status, it turns off the light.

Details as below picture:

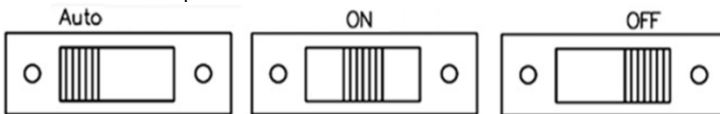

**Note:** before delivery set Auto

### •BIT1- BIT4: Steady burning/Flashing switch:

Dial switch 1-4, it separately controls the 4 circuit branch lights working status(steady burning/flashing). Toggle the switch to ON, all the circuit branch will be steady burning; Toggle the switch to OFF, all the circuit branch will be flashing.

Picture								
Working mode	Light 1 flashing	Light 1 steady burning	Light 2 flashing	Light 2 steady burning	Light 3 flashing	Light 3 steady burning	Light 4 flashing	Light 4 steady burning

**Note:** before delivery set 1~4 flash.

### •BIT5、BIT6: Flashing rate settings:

Dial switch 5 & 6, it could set the circuit branch light's flashing rate.

Picture				
Fash Rate	20 FPM	30 FPM	40 FPM	60 FPM

**Note:** The factory setting is 40 FPM.

### •BIT7: Main& standby switch set:

Dial switch 7 can set control cabinet 1,2 main&standby light switch.

Picture		
Control	Lamp1 normal light, lamp2 normal light	Lamp 1 main light, lamp 2 standby light

**Note:** before delivery set lamp1, lamp 2 are normal light.

# FR104 Obstruction Light Controller



- BIT8: main&standby light switch set:  
Dial switch 8 can set control cabinet 3,4 main& standby light switch.

Picture		
Control	Lamp 3 normal light, Lamp4 normal light	Lamp3 main light,lamp4 standby light

**Note: before delivery set lamp3, lamp 4 are normal lights.**

## Fault alarm function

- Control cabinet is not connect power supply or light fault: Relay does not move, "common" and "normally closed" are closed, see below picture:

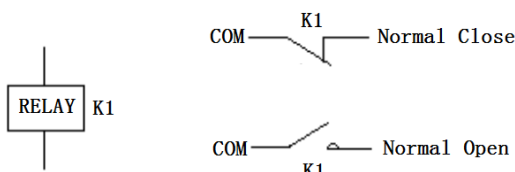

- Control cabinet is connected to the power supply and it is working normally: Relay action, "common" and "normally open" closed,see below picture:

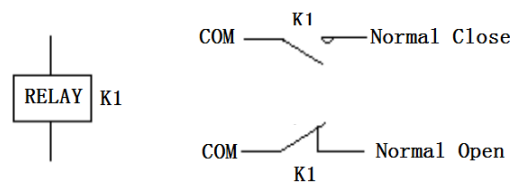

- If there is no power supply access, or failed received "disconnected" signal, alarm signal wire is connected to "common" + "normally open";
  - If there is no power supply access, or failed received "closed" signal, alarm signal wire is connected to "common" + "normally closed"
- Note: Photocell no change in 24-hour detection is considered a failure.**

- Fault indicate:

Alarm LED ( red ) : When the branch light fails,Alarm LED red indicator light, Fault startup time is related to the set frequency, The relationship is as follows:

- 60FPM Main lamp failure start time is about 60S
- 40FPM Main lamp failure start time is about 90S
- 30FPM Main lamp failure start time is about 120S
- 20FPM Main lamp failure start time is about 180S

Alarm LED ( Green): When the branch lights work normally, the Alarm LED green indicator is on

**Note: Main& standby working, when main light normal working, standby light indicate yellow. When main light failed, Alarm LED red indicator on. Meanwhile standby Alarm LED green indicator on, switch to standby working.**

- Initial data calibration:

The first time the lamp is turned on (initially installed or replaced), the "Study" button must be pressed to learn.

After the power is turned on, press the "Study" button after the lamp works normally, the buzzer will sound a "drip", indicating that the calibration is started. During the calibration, the branch circuit and the load voltage and current parameters cannot be disconnected. The calibration time is 30s. . After the calibration is completed, if the buzzer sounds "drip" two times, the calibration is successful. If the buzzer sounds "drip" five or ten sounds, it means the calibration failed. Check the external circuit and re-adjust the external circuit if there is no fault.

Thanks for choosing our products, **NANHUA Electronics** brands specially focus on signal transmission and high quality industrial lighting, we are deeply trusted and favored by different fields customers all over the world. Please be sure you have read and fully understand the product instruction to operate the product. Incorrect installation and use will cause fire, electric shock and other danger. Please understand for not timely informing because of the product improvement, model and style modification.

©NANHUA Electronics Co., Ltd. All rights reserved. [www.nanhua.com](http://www.nanhua.com)