

LW52 LED Emergency Light



Products description and application

The LW52 series is a versatile LED light designed to meet various industrial needs. It is suitable for operator's cab and walkway of large port machinery (RTG, gantry crane, container crane), internal lighting for wind turbines, ship cabin roof and walkway lighting.

Compliance: IEC60598-1\IEC60068-2\IEC60529\IEC62262\EN55015

Features

- Compact and lightweight design.
- Wide light distribution minimizes dark spots and glare without eye discomfort.
- Polyurethane housing for enhanced corrosion resistance.
- Tempered glass lampshade for impact resistance.
- Waterproof breathable valves and anti-siphon cables for superior dust-proof and waterproof performance.
- Selection of high-quality LED chips and power supplies with higher efficiency and longer lifespan.

General Specifications

Standard

CE: EN 60598-1、EN 60598-2-1、EN 60598-2-22、EN 60493、EN 55015、EN 61547、EN 61000-3-2、EN 61000-3-3

Electrical		Mechanical	
Operating voltage	100-240VAC	Housing color	Silver gray
Frequency	50/60Hz	Housing material	Aluminum alloy
Power consumption	12W/22W	Cover material	Tempered glass
PF	>0.75	Weight	0.8kg
EMC	IEC61000-4-2 Contact discharge	Mounting	Flat Mount 2-M8
	$\pm 4\text{kV}$, Air discharge $\pm 8\text{kV}$	Operating temperature	$-30^{\circ}\text{C} \sim +50^{\circ}\text{C}$
	IEC61000-4-4 $\pm 2\text{kV}$	Vibration resistant rate	IEC60068 3g
	IEC61000-4-5 L-N: $\pm 2\text{kV}$	IP rate	IEC60529 IP65
Wiring	L,N-PE: $\pm 4\text{kV}$	Salt spray rate	ISO9227 NSS 720h
	lead wire		
Photometric			
Light source	LED	LEDs lifetime	$\geq 50000\text{h}$
CCT	5700K	Beam angle	$160^{\circ} \times 55^{\circ}$
CRI	$R_a \geq 70$	Lumen per Watt	100lm/W
Luminous	1200lm/2400lm		
Emergency luminous	200lm/400lm		

^[1] 25°C can meet the emergency time more than 90 minutes.

LW52 LED Emergency Light



Mounting dimensions

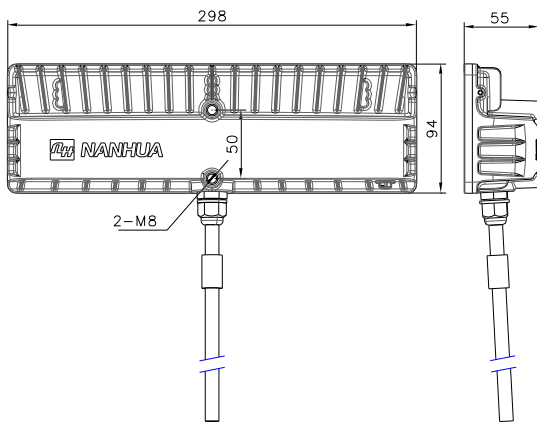

Installation:

- Check that the power supply and the lamp's rated voltage match.
- Use 2 M8 screws to fix the lamp on the mounting surface. Please make sure that the mounting surface is strength enough.
- Refer to the wiring diagram for the power connections:

L1 and N are for regular lighting inputs;

L2 and N are for emergency inputs;

The on/off switch of L1 controls the light.

In the event of main power disconnection, the lamp will activate the emergency function.

- No specific installation height requirements.

Wiring diagram

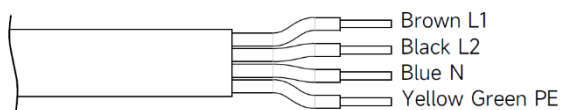

Precautions:

- This product will have a slight temperature rise when it is working, which is normal.
- Ensure L2 is connected to the power supply for normal operation, allowing L1 to control the light.
- When L2 is not connected to the main power, activating the emergency switch will not trigger the emergency function.
- Don't open any parts of the lamp when it is working to avoid any anger.
- The lamp's battery has a consumable cycle life (IEC61960-3 2017) of 500 times; it is advisable to perform maintenance by charging and discharging the product every three months.
- Retain the nylon waterproof coating when cutting the lead wire.
- This product has a sealed structure and disassembly or assembly must be performed by professionals. Any such attempts will void the warranty.

Distribution curve flux

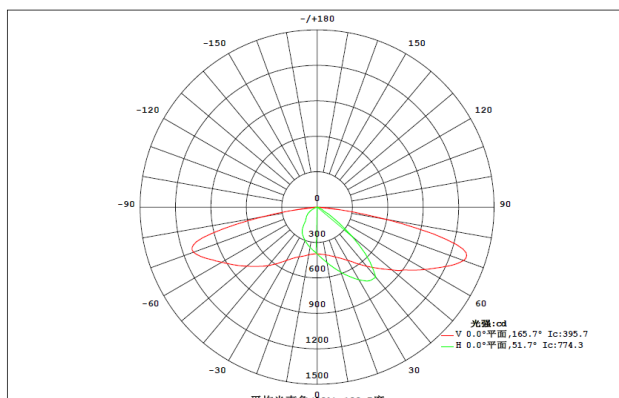

LW52 LED Emergency Light



Selection table

LW52-①②③

① Function

Y:Emergency

② Voltage

A:100-240VAC

③ Power

12:12W

22:22W

How to Order

P/N	Model	Voltage	Power	Color temp	Beam angle	Wire method	Mounting
-----	-------	---------	-------	------------	------------	-------------	----------